



FEL Carry Can

Mobile Refuse Cart Lifter

Bayne offers a full line of patented **FEL Carry Cans** to fit all OEM truck models. In addition to the patented Thinline[®] rack and pinion rotary actuator, Bayne also holds a patent on the combination of a cart lifter with an FEL Carry Can, thus allowing the hauler to operate one truck for both residential and commercial routes resulting in a reduction of total fleet cost. The FEL Carry Can has a 3 cubic yard capacity for less dump cycles and cart lifters can be mounted on the curb side and/or front of the carry can. FEL Carry Cans are constructed of 12 gauge steel for durability.

- Compatible with both semi-automated and fully automated roll-out carts
- Designed to provide close access to containers on the curb
- Quick disconnect fittings allow for easy removal of the carry can when changing from residential to commercial routes
- Places cart to the center of the carry can when dumping to prevent spillage
- Powder-coated finish for durability
- 2-Year Limited Warranty



Premium Lift Systems

Precision, Quality and...Patented Engineering!

FEL Carry Can

Specifications and Dimensions

Cart Compatibility:	ANSI Z245.60-1996 Type B Carts (domestic style 2-bar) ANSI Z245.60-1996 Type C Carts (European style) ANSI Z245.60-1996 Type D Carts (pocketed style) ANSI Z245.60-1996 Type G Carts (automated style) Standard size 30 and 55 gallon drums
Lift Capacity:	400 lbs @ 1800 psi
Hydraulic Pressures:	Working Pressure – 1800 psi Maximum Pressure – 2500 psi
Hydraulic Flow:	2.0 – 2.5 gpm
Cycle Time:	6 – 8 seconds 10 – 12 seconds (GTL / VBTL)
Bearings:	Self-Lubricating Composite Material
Actuator:	Patented Thinline® Rack and Pinion Rotary Actuator
Finish:	Safety Yellow Powder Coating
Options:	• Hydraulic Tap-In Kit

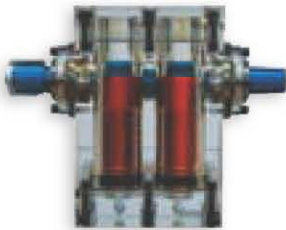

Patented Thinline®
Rack and Pinion
Rotary Actuator



CONSOLIDATED DISPOSAL
SYSTEMS, INC.

P. O. Box 813154
Smyrna, GA 30081
PHONE: 404-696-1530 or
800-844-1530
FAX: 404-696-1608

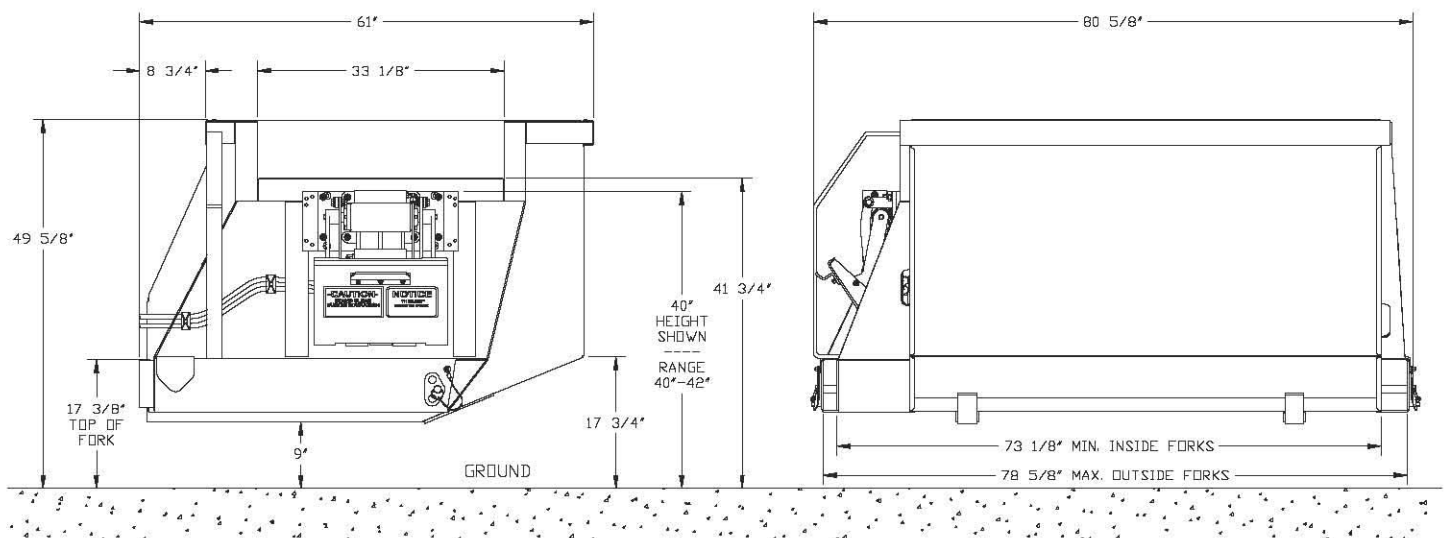

Bayne Premium Lift Systems

208 Fairforest Way, Greenville, SC 29607 • www.baynethinline.com
Toll Free: 800.535.2671 • Local: 864.288.3877 • Fax: 864.458.7519

© 2005, Bayne Premium Lift Systems
Printed in U.S.A. Form #BLS-09-001-041505