

MBTL Series



Mobile Refuse Cart Lifter

The **MBTL 180** takes one of the best selling, most dependable lifters from **Bayne Premium Lift Systems** and makes it even better. This lifter offers all the best characteristics of the original MBTL, like industry leading ground clearance, solid hook drive mechanism and no packer blade interference. However, with its improved dump height and depth, the MBTL 180 prevents spillage and increases route stops before cycling packer blade.

- Powered by the patented Thinline® rack and pinion rotary actuator for smooth operation
- Compatible with standard domestic style 2-bar roll-out carts
- Solid hook drive mechanism automatically secures the cart to the lift plate during the dump cycle
- Over 19" of ground clearance reduces the risk of damaging the lifter on uneven terrain
- Sweeping motion for increased cart pick-up envelope
- Will not interfere with packer blade when properly mounted
- Powder-coated finish for durability
- 2-Year Limited Warranty



Premium Lift Systems

Precision, Quality and...Patented Engineering!

MBTL Series

Specifications and Dimensions

Cart Compatibility:	ANSI Z 245.60-1996 Type B Carts (domestic style 2-bar)
Lift Capacity:	400 lbs @ 1600 psi
Hydraulic Pressures:	Working Pressure – 1600 psi Maximum Pressure – 2500 psi
Hydraulic Flow:	2.0 – 2.5 gpm
Cycle Time:	6 – 8 seconds
Bearings:	Self-Lubricating Composite Material
Actuator:	Patented Thinline® Rack and Pinion Rotary Actuator
Finish:	Safety Yellow Powder Coating
Options:	<ul style="list-style-type: none"> • Tap-In-Kit • Mounting Plate Kit for Bolt-On Application • Commercial Container Bumper Kit



Patented Thinline®
Rack and Pinion
Rotary Actuator

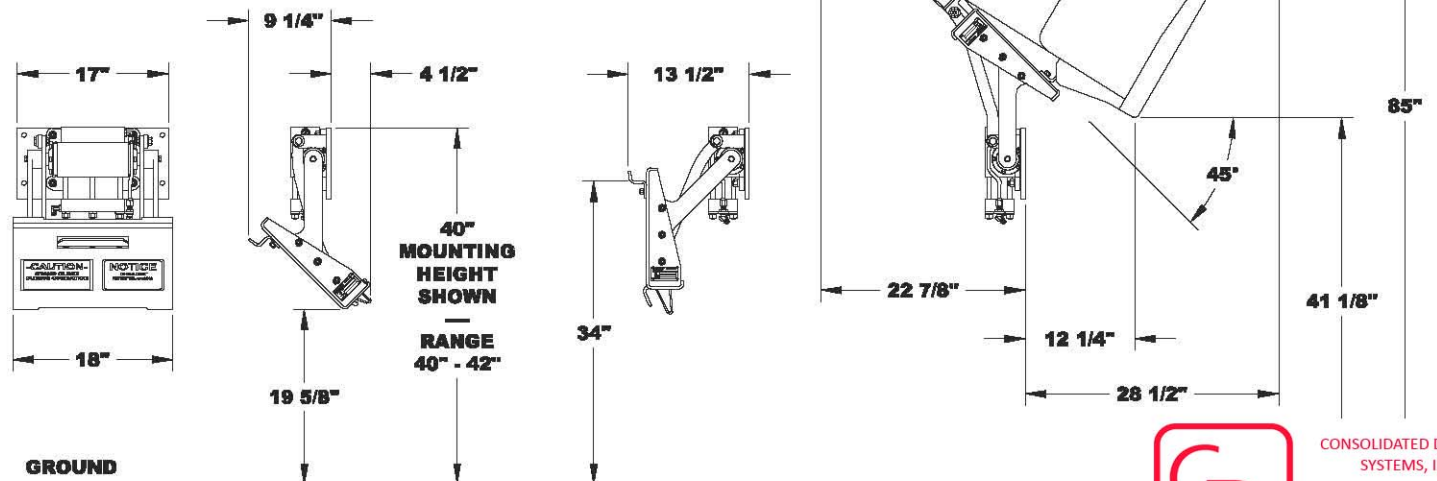

CONSOLIDATED DISPOSAL
SYSTEMS, INC.

P. O. Box 813154
Smyrna, GA 30081
PHONE: 404-696-1530 or
800-844-1530
FAX: 404-696-1608

Bayne Premium Lift Systems

208 Fairforest Way, Greenville, SC 29607 • www.baynethinline.com
Toll Free: 800.535.2671 • Local: 864.288.3877 • Fax: 864.458.7519

© 2005, Bayne Premium Lift Systems
Printed in U.S.A. Form #BLS-03-001-041505