

Priced To Compete Made To Last

Value Added Features

- Injection molded for extra strength and durability
- 0.175 minimum wall thickness
- Extra wall thickness in bar area
- Rotating steel bar for less stress on cart body
- Non-slip, textured finish on corners for grabber efficiency
- Smooth surface inside and out for easy cleaning
- Comfortable, ergonomic handles
- Long-lasting integrated lid hinges
- In-molded bar supports
- In-molded reinforced sleeve
- 7/8" solid steel axles
- 3/8" bottom wear strip for longer life
- Sealed lids to keep in odors
- Overlapping lid for rain protection



You can put Schaefer carts on your route and forget about them. Our injection molded carts last and last. You won't be working overtime with warranty replacements or repairs.

- Sized right – in 35, 65 and 95 gallon capacities
- Carts work smoothly with all types of lift systems

Ask for the cart that will save you money now and be trouble free.
Get more for your money. Call Schaefer today.

SSI SCHAEFER
SYSTEMS INTERNATIONAL, INC.



Consolidated Disposal Systems, Inc.
Smyrna, GA
Dan Jane- 770-402-3945

**Strong.
Smart.
Schaefer.**



Strong. Smart. Schaefer.



Consolidated Disposal Systems, Inc.
Smyrna, GA
Dan Jane- 770-402-3945

Schaefer Universal System Design Cart

Model USD-B: for use with standard bar-lock lifters or automated grabbers

Model USD-C: for use with comb lifters or automated grabbers

A Body

- Non-slip, textured finish on corners for grabber efficiency
- 0.175" or greater wall thickness for durability
- Long-lasting, integrated lid hinges
- Smooth surface inside and out for easy maintenance
- Injection molded for maximum strength and durability
- One piece high density polyethylene (HDPE) construction



B Bar

- Highly durable, in-molded bar supports
- Freely rotating steel bar for less stress on cart body
- Unique self-centering feature for easy assembly
- Extra wall thickness in bar area for durability



C Upper Attachment

- In-molded reinforced sleeve for bar-lock lifters or
- In-molded reinforced frontal rim for comb lifters
- In-molded support ribs for reinforcement



D Lids

USD 35

- New, easy open lid design
- Patented moisture ring
- Overlapping lip for rain protection
- Inside dripping rim to seal in odors
- 270° lid opening
- Groove for adding neoprene seal
- Options include:
 - front mounted paper slot
 - side mounted ventilation for yard waste
 - neoprene seal for hazardous waste



USD 65 & USD 95

- Overlapping lip for rain protection
- Inside dripping rim to seal in odors
- 270° lid opening
- Sturdy, comfortable ergonomic handles

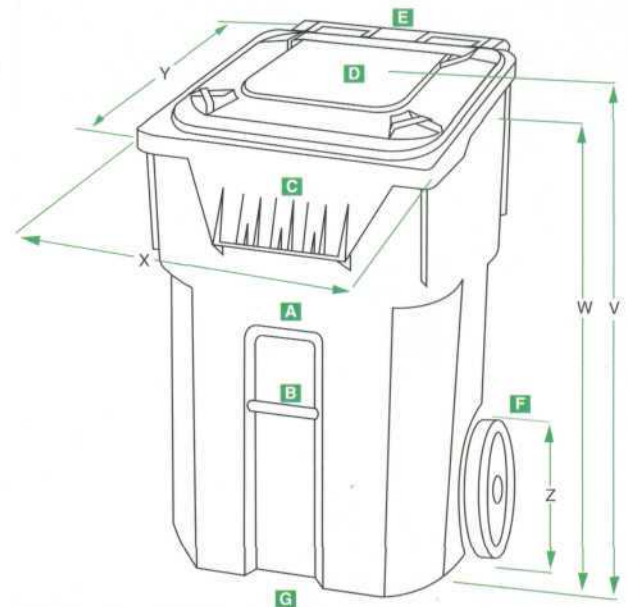

Dimensions		USD 35	USD 65	USD 95
Overall Height	V	36.25"	42.2"	46.5"
Cart Body Height	W	25.0"	39.5"	43"
Overall Width	X	22.75"	28"	28"
Overall Depth	Y	22.35"	26.8"	30.5"
Wheel Diameter	Z	8"	8" or 10"	12"
Load Rating		125 lbs.	220 lbs.	340 lbs.

E Handles

- In-molded, integral hand grips for pushing/pulling the cart
- Smooth surface with no protrusions
- 2" x 5" opening for easy gripping



5 gallon insert in 65 gallon container for recycling glass

F Wheels and Axles

- 7/8" axle of tempered, rolled, cut, galvanized solid steel
- Maintenance-free bearings lubricated for life
- 12" wheels on 95-gallon model
- 8" or 10" wheels on 65-gallon model

G Bottom

- In-molded toe hold to ease tilting of loaded cart
- 3/8" wear strip for longer life

E Colors and Marking

- Available in green, blue, brown and charcoal
- Custom colors available
- Smooth surface for hot stamping on lid and body



20 gallon insert in 35 gallon container for collection of recyclables

SSI SCHAEFER
SYSTEMS INTERNATIONAL, INC.